

Metal X (Gen 2)

The Metal X is a revolutionary 3D printer that prints metal powder bound in a plastic matrix to eliminate safety risks associated with traditional metal 3D printing methods while enabling new features like close-cell infill for reduced part weight and cost. It's up to 10x less expensive than alternative metal additive manufacturing technologies — and up to 100x less than traditional fabrication technologies like machining or casting. Affordable, reliable, and easy to use, the Metal X print system gives you everything you need to go from design to fully functional metal parts faster than ever before.

Printer Properties	Process	Metal fused filament fabrication
	Build Volume	300 x 220 x 180 mm (11.8 x 8.7 x 7.1 in)
	Machine Size	575 x 467 x 1,120 mm (22.7 x 18.4 x 44.1 in), 75 kg (160 lbs) Touchscreen: 12 cm (4.7 in) horizontal extension
	Print Chamber	Heated
	Print Bed	Heated, vacuum-sealed print sheet, auto bed leveling
	Print System	Two nozzles — Metal material and release material
	Power Requirements	100–120 / 200–240 VAC (12A / 6A), IEC 60320 type C20
	RF Module	Operating Band 2.4 GHz Wi-Fi Standards 802.11 b/g/n
Materials	Metal Material	Stainless steel (17-4 PH), Tool steel (H13, A2, D2), Inconel 625, Copper
	Release Material	Ceramic (consumed at 1:10 ratio to metal spools, on average)
	Media (Spools)	Filament fed, bound powder
Part Properties	Max Part Size	250 x 183 x 150 mm (9.8 x 7.2 x 5.9 in), 10kg
	Supports	Metal material with ceramic release layer
	Layer Height	50µm and 125µm post-sinter
Software	Supplied Software	Eiger Cloud (Other options available at cost)
	Security	Two-factor authentication, org admin access, single sign-on

FRONT VIEW

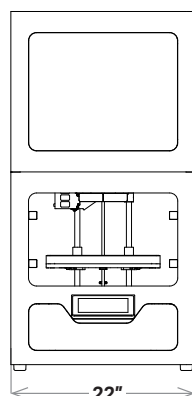

SIDE VIEW

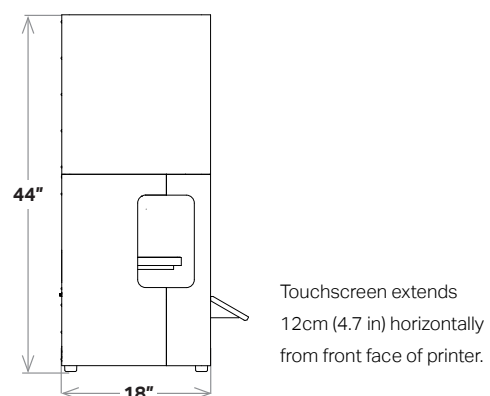

Note: All specifications are approximate and subject to change without notice.