

PRODUCT SPECIFICATIONS

X7 (Gen 2) Field Edition

The X7 Field Edition is a ruggedized, field-deployable industrial 3D printer designed for tactical response to inventory challenges in remote locations. Increase supply chain resilience by printing tools, adapters, and replacement parts for equipment at the point of need.

Printer Properties	Printer Model	X7 (Gen 2)
	Process	Fused Filament Fabrication, Continuous Filament Fabrication
	Build Volume	330 x 270 x 200 mm (13 x 10.6 x 7.9 in)
	Case Weight	86 kg (189 lbs)
	Case Footprint	914 x 914 x 762 mm (36 x 36 x 31 in)
	Print Bed	Kinematic coupling — flat to within 80 µm
	Laser	In-process inspection, active print calibration, bed leveling
	Extrusion System	Second-generation extruder, out-of-plastic and out-of-fiber detection
	Power	100–240 VAC, 150W (2A peak)
	RF Module	Operating Band 2.4 GHz Wi-Fi Standards 802.11 b/g/n **
Materials	Plastics Available	Onyx, Onyx FR, Onyx ESD, Nylon White
	Fibers Available	Carbon Fiber, Carbon Fiber FR, Fiberglass, Aramid Fiber (Kevlar®), HSHT Fiberglass
	Tensile Strength	800 MPa (25.8x ABS, 2.6x 6061-T6 Aluminum) *
	Tensile Modulus	60 GPa (26.9x ABS, 0.87x 6061-T6 Aluminum) *
Part Properties	Layer Height	100 µm default, 50 µm minimum, 250 µm maximum
	Infill	Closed cell infill: multiple geometries available
Software	Eiger Cloud	Slicer, part / build management (other options available at cost)
	Security	Two-factor authentication, org admin access, single sign-on
	Blacksmith	Adaptive manufacturing platform (additional purchase required)

FRONT VIEW (DEPLOYED)

SIDE VIEW (DEPLOYED)

FRONT VIEW (PACKED)

SIDE VIEW (PACKED)

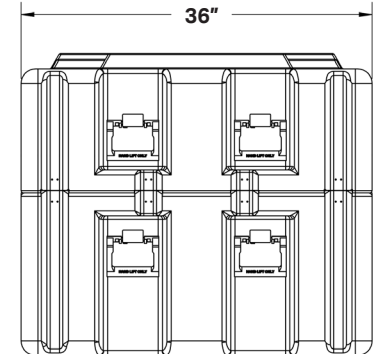
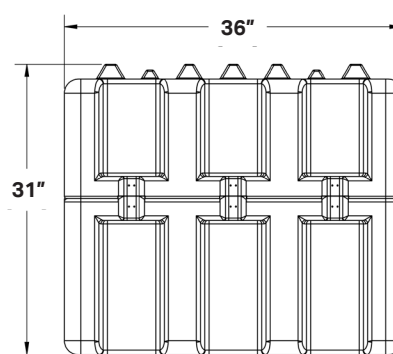
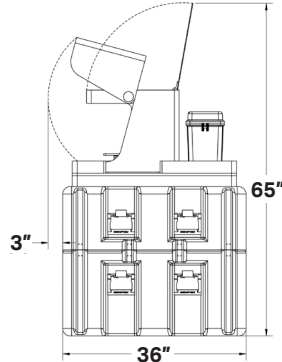
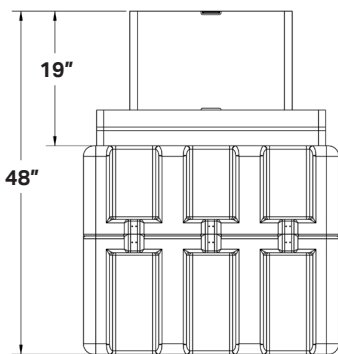

* Continuous carbon fiber data. **Note:** All specifications are approximate and subject to change without notice. ** No-wifi version available. Dupont™ and Kevlar® are trademarks and registered trademarks of E.I. du Pont de Nemours and Company.